

SECTION - A : PHYSICS

This section contains **15 Multiple Choice Questions**. Each question has four choices (1), (2), (3) and (4) out of which **ONLY ONE** is correct.

1. Four students stand facing a box. The diagram below shows an overhead view of the box. The numbered circles represent the positions of the students.

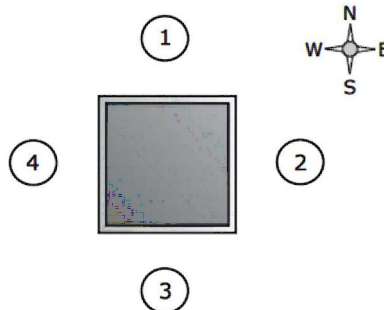

What do the students need to do to slide the box to the northeast?

- (1) Students 1 and 2 push, and Students 3 and 4 pull
 - (2) Students 1 and 4 push, and Students 2 and 3 pull
 - (3) Students 2 and 3 push, and Students 1 and 4 pull
 - (4) Students 3 and 4 push, and Students 1 and 2 pull
2. How many images will be formed in the figure shown, when the object is kept at O ?

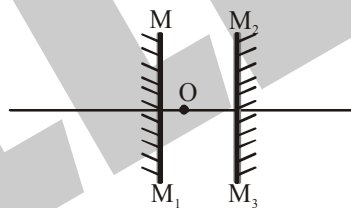

- (1) Zero
 - (2) Infinite
 - (3) Three
 - (4) Ten
3. The picture below shows the four major forces acting on an airplane in flight.

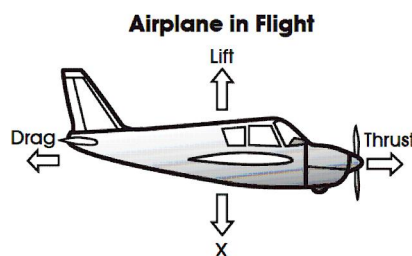

What causes the force indicated by the X ?

- (1) gravity
 - (2) air friction
 - (3) magnetic force
 - (4) force exerted by the engine
4. A person is standing between two parallel plane mirrors kept 3 m apart. What will be the distance between 1st images formed in the mirrors ?
- (1) 1.5 m
 - (2) 3 m
 - (3) 6 m
 - (4) cannot be answered as position of person is required

5. At what temperature a Fahrenheit thermometer be double than that of Centigrade thermometer ?
 (1) 160 °C (2) -40 °C (3) 40 °C (4) -160 °C
6. Four pots of water are put on a stove. Each pot is heated with the same heat setting.

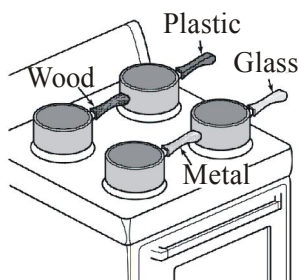

Which handle will most likely be the hottest after five minutes?

- (1) Wood (2) Plastic (3) Metal (4) Glass
7. A pendulum oscillate 40 times in 4 sec. Find its frequency.
 (1) 40 Hz (2) 10 Hz (3) 4 Hz (4) 1 Hz
8. Which observation demonstrates that light waves travel much faster than sound waves?
 (1) An exploding firework is seen before it is heard
 (2) Light from the Sun takes eight minutes to reach Earth.
 (3) Thunder can be heard before lightning is seen.
 (4) A returning echo is heard after a splitsecond delay.
9. Which diagram best shows the reflection of light?

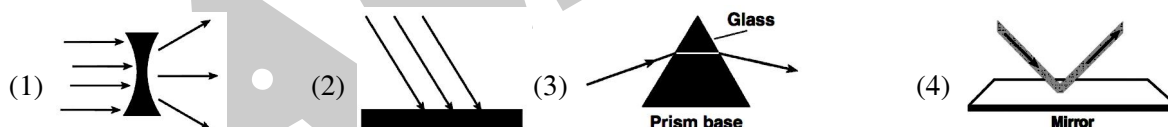

10. The graph below represents the motion of a runner during a 2000-meter race.

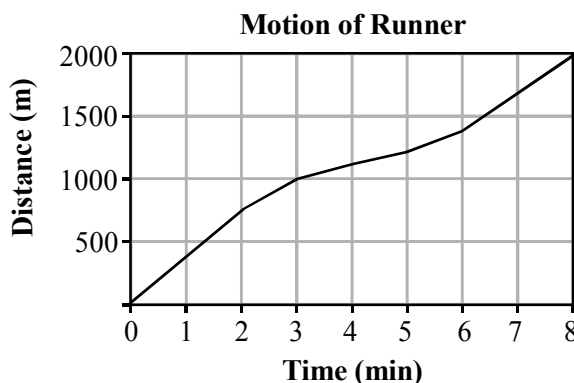

During which of the following time periods is the runner's speed is constant?

- (1) 0-8 min (2) 2-8 min (3) 4-8 min (4) 6-8 min

14. A student follows the route shown in the diagram and arrives back at the starting point.

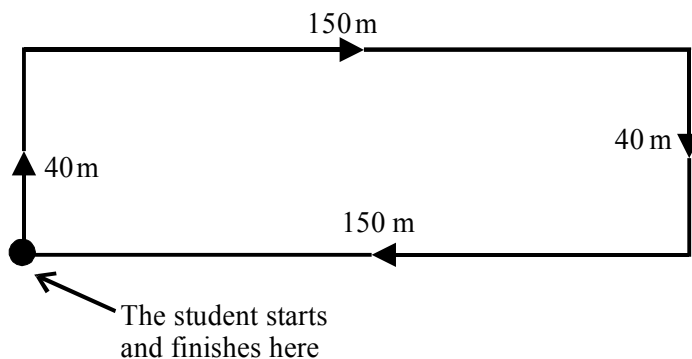

Which row in the table shows the total distance walked and the magnitude of the final displacement?

	Total distance (m)	Final displacement (m)
(1)	0	80
(2)	0	380
(3)	190	0
(4)	380	0

15. The diagram below shows an electric circuit.

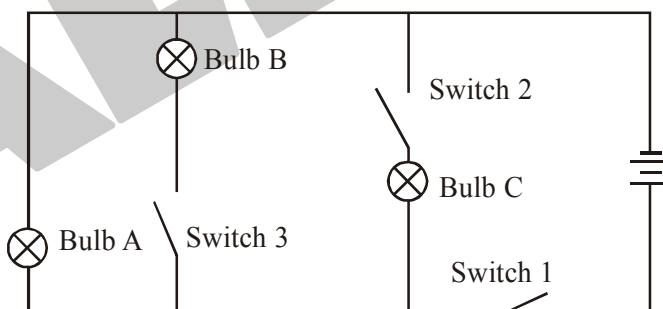

In which order must you close the switches so that bulb A lights up first, followed by bulb B and then bulb C ?

	First	Second	Third
(1)	Switch 1	Switch 2	Switch 3
(2)	Switch 3	Switch 2	Switch 1
(3)	Switch 2	Switch 3	Switch 1
(4)	Switch 1	Switch 3	Switch 2

SECTION-B : CHEMISTRY

This section contains **15 Multiple Choice Questions**. Each question has four choices (1), (2), (3) and (4) out of which **ONLY ONE** is correct.

16. In the given reaction.

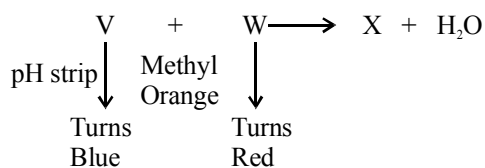

V, W, X are respectively.

- | | | |
|-----------------------|---------------|-----------------------|
| (1) CaCO_3 | HCl | CaCl_2 |
| (2) Mg(OH)_2 | NaOH | Na_2O |
| (3) Ca(OH)_2 | HCl | CaCl_2 |
| (4) MgCO_3 | HCl | MgCl_2 |
17. Arrange the pairs in sequence in decreasing order of basicity of an acid and acidity of a base followed by salts formed by the given acid base pairs in the same order respectively.
- | | |
|--|-----------------------------------|
| (a) Acetic acid, ammonium hydroxide | (b) Oxalic acid, barium hydroxide |
| (c) Phosphoric acid, aluminium hydroxide | (d) Barium oxalate |
| (e) Ammonium acetate | (f) Aluminium phosphate |
- (1) adcfbe (2) cbafde (3) adcebf (4) cdaebf
18. I am easy to wash, absorbs very little water and have a very lustrous, appearance. I am used to make bristles of tooth brushes, combs etc. Since I am so versatile you must know me. Who am I ?
- (1) Rayon (2) Dacron (3) Terylene (4) Nylon
19. When few granules of sample X are added to a solution of copper sulphate, the changes observed are shown in the figure. Identify sample X and red deposit respectively.

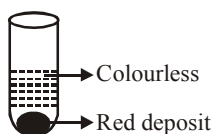

- (1) Fe, Zn (2) Fe, Cu (3) Cu, Zn (4) Zn, Cu
20. Ramesh mixed some iron fillings with sulphur powder in a china dish. In another dish he mixed iron fillings and sulphur powder and heated the mixture. Which of his observations is 'NOT' correct?

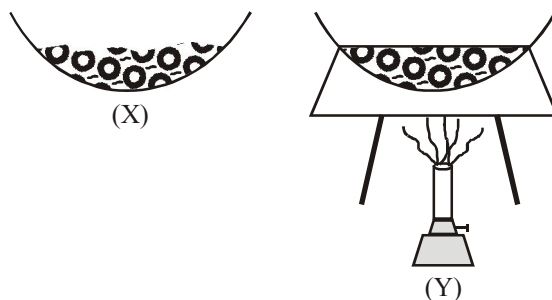

- (1) Dish X shows a physical change while dish Y shows a chemical change.
 (2) In dish X sulphur powder and iron fillings can be seen separately.
 (3) In dish Y a new substance is formed on heating the mixture.
 (4) The change which has taken place in dish Y is reversible.

21. Which the following water does not contain dissolved gases such as oxygen and carbon dioxide ?
 (1) Potable water (2) Distilled water (3) Saline water (4) Soft water
22. Kanav took two test tubes marked as I and II. In test tube I, he put calcium carbonate and hydrochloric acid while in test tube II, he put zinc granules and hydrochloric acid. He passed the gas coming out from both the test tubes in lime water. What are his observations ?

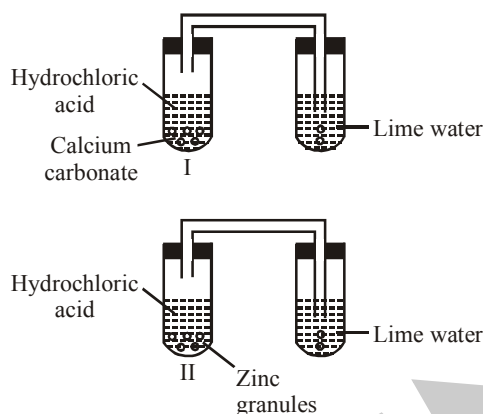

- (1) The gas coming out from test tube I turns lime water milky.
 (2) The gas coming out from test tube II turns lime water milky.
 (3) The gas coming out from both the test tubes turns lime water milky.
 (4) None of these
23. A few elements in the order of decreasing reactivity are: $K > Ca > Mg > Fe > Sn > H > Au$. Identify the incorrect statement.
 (1) Au is the weakest reducing agent.
 (2) Tin from tin oxide can be displaced by Fe.
 (3) Ca displaces hydrogen from water more easily than Fe.
 (4) K is the strongest oxidising agent.
24. Riya described a fabric as following.
- It absorbs water quickly.
 - It is soft to touch.
 - It creases easily.
 - It can be washed and ironed easily.
 - It is obtained from plant sources.
- Which of the following fibre can form such fabric ?
 (1) Cotton (2) Silk (3) Wool (4) Nylon
25. Ammonia is found in many household products, such as window cleaners. It turns red litmus blue, what is its nature ?
 (1) Basic (2) Acidic (3) Neutral (4) None of these
26. The hard plastic covers of telephones are made of polymers
 (1) styrene (2) acrylonitrile (3) ethene (4) none of these
27. What is infiltration ?
 (1) Precipitation of water (2) Process of filtering of water
 (3) Seeping of water into the ground (4) Evaporation of water

28. We use PET bottles. PET jars are used for storing sugar, dal, salt etc. What is this PET exactly ?
 (1) Familiar form of phenol (2) Familiar form of polyester
 (3) Familiar form of resin (4) Familiar form of polygon
29. An element X does not react with dilute sulphuric acid. If it forms an oxide XO, which turns moist red litmus into blue, what would we call X ?
 (1) A metal (2) A non-metal (3) An acid (4) Noble gases
30. Which of the following methods cannot be used to prevent rusting?
 (1) Painting (2) Alloying (3) Galvanisation (4) Crystallisation

SECTION-C : BIOLOGY

This section contains **15 Multiple Choice Questions**. Each question has four choices (1), (2), (3) and (4) out of which **ONLY ONE** is correct.

31. 'X' is a blood vessel that carries blood rich in carbon dioxide. 'Y' is a blood vessel that carries digested food and water. 'Z' is a blood vessel with very thin walls so that oxygen can pass through easily. What can 'X', 'Y' and 'Z' be ?

- | | | |
|------------|-----------|-----------|
| 'X' | 'Y' | 'Z' |
| (1) Artery | Vein | Capillary |
| (2) Vein | Capillary | Artery |
| (3) Vein | Artery | Capillary |
| (4) Heart | Lung | System |

32. Which of the following device used by a doctor to check the heart beat ?

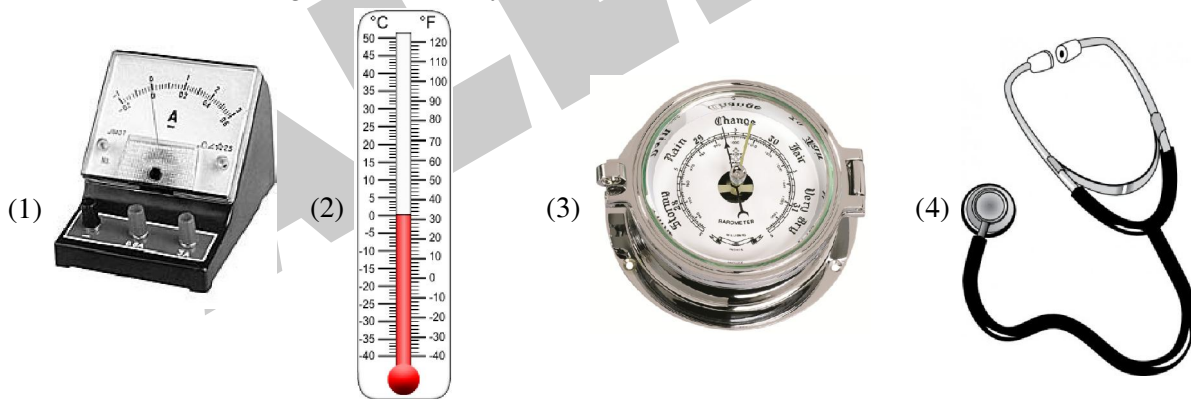

33. The diagram below represents a food chain made up of organisms found in a field.



Which of the following row in the chart correctly identifies characteristics that can be associated with the members of this food chain?

	Producer	Consumer	Autotroph	Heterotroph
(1)	corn	snake	mouse	owl
(2)	mouse	owl	snake	mouse
(3)	corn	owl	corn	snake
(4)	owl	corn	snake	corn

34. A food web is represented below.

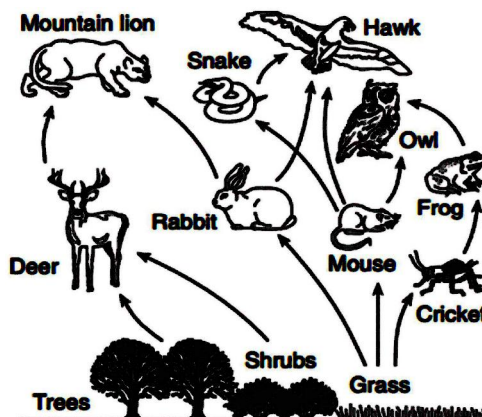

A continuous decrease in the number of the rabbit population would most likely cause a decrease in which other population?

- (1) Frog (2) Mountain lion (3) Grass (4) Cricket

35. The given figure illustrated the effect of exhaled air on lime water.

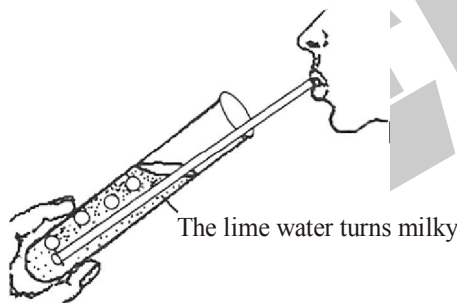

Lime water turns milky due to the presence of _____ in exhaled air.

- (1) carbon monoxide (2) carbon dioxide
 (3) nitrogen (4) oxygen

36. Process A and B occur in green plants. The symbol '✓' means it takes place while '✗' means it does not take place.

Process	Daytime	Nighttime
A	✓	✗
B	✓	✓

What processes do A and B represent ?

- | A | B |
|--------------------|----------------|
| (1) Breathing | Respiration |
| (2) Respiration | Photosynthesis |
| (3) Photosynthesis | Respiration |
| (4) Transpiration | Photosynthesis |

37. The words given below in the box belong to which of the following practices?

Plough, Hoe, Cultivator

- (1) Soil preparation (2) Sowing
 (3) Irrigation (4) Threshing

38. Match the column I with column II and choose the correct option.

Column I		Column II	
a	Rinderpest	i	Fowl birds
b	Typhoid	ii	Fresh water fish
c	Rust of wheat	iii	Cattle
d	Mrigal	iv	Fungi

(1) a-iii, b-i, c-iv, d-ii (2) a-ii, b-i, c-iv, d-iii (3) a-iii, b-ii, c-iv, d-i (4) a-ii, b-iii, c-iv, d-i

39. Wrap the leaves of a potted plant with polythene bag. Remove the bag after four days. What will you observe ?

- (1) Polythene bag becomes green in colour.
 (2) All the leaves inside polythene bag are shed.
 (3) Polythene bag has droplets of water on its inner surface.
 (4) All of these

40. Which one is showing modern method of irrigation ?

- (1) Dhekli (2) Rahat (3) Moat (4) Sprinkler system

41. Structures in an animal cell are represented in the diagram given below.

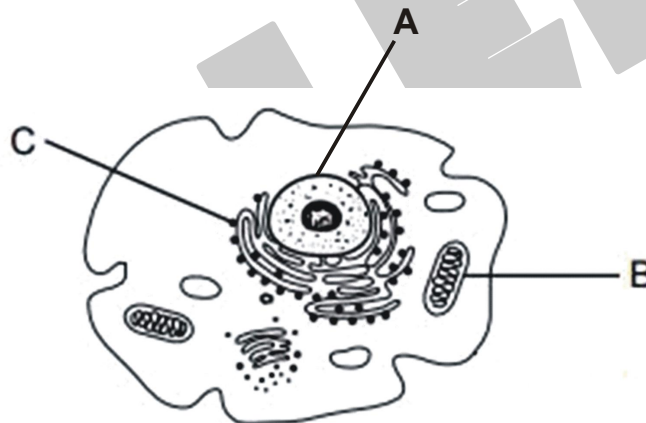

Which row in the chart correctly identifies the functions of structures A, B, and C?

	Structure A	Structure B	Structure C
(1)	controls the activities of cell	produce energy currency	protein synthesis
(2)	information storage	transport of materials	storage of liquids
(3)	protein synthesis	storage of waste	reproduction
(4)	cell communication	transport of materials	waste removal

42. Match the Column-I with Column-II and select the correct option from the codes given below.

Column-I		Column-II	
a	Suicidal bag of the cell	(i)	Mitochondria
b	Power house of the cell	(ii)	Ribosome
c	Protein factory of the cell	(iii)	Lysosome
d	Kitchen of the cell	(iv)	Endoplasmic reticulum
e	Circulatory system of the cell	(v)	Chloroplast

- (1) a-(iii), b-(i), c-(ii), d-(iv), e-(v) (2) a-(iii), b-(i), c-(iv), d-(v), e-(ii)
 (3) a-(iii), b-(i), c-(ii), d-(v), e-(iv) (4) a-(i), b-(iii), c-(ii), d-(v), e-(iv)

43. The classification diagram below shows the different parts of a typical cell, X. Some parts of the cell are not shown in the diagram.

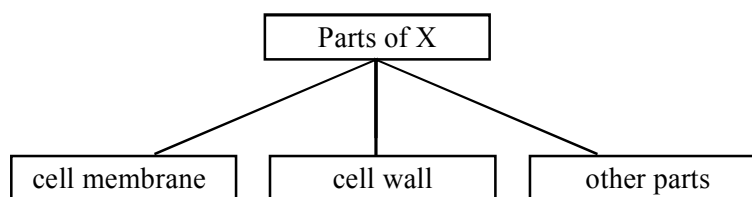

Which is/are the most likely parts of cell X not shown in the classification diagram above ?

- A. Mitochondria
- B. Nucleus
- C. Chloroplasts

- (1) A (2) A & B (3) B & C (4) A, B & C

44. Bacteria are often classified according to their shape. Which type of bacteria cause tuberculosis?

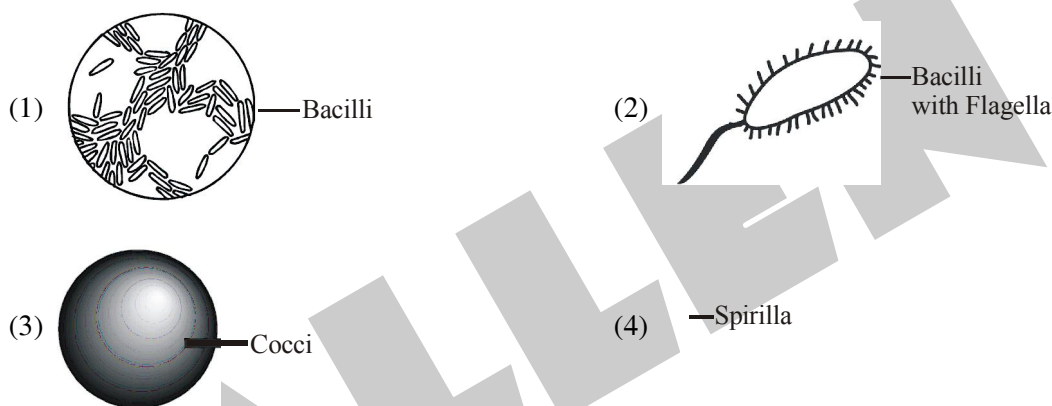

45. Some diseases and their causing factor are given below. Choose the incorrect option.

	DISEASE	CAUSING FACTOR
(1)	Sleeping sickness	<i>Mycobacterium tuberculosis</i>
(2)	Plague	<i>Yersinia pestis</i>
(3)	Elephantiasis	<i>Filarial worm</i>
(4)	Typhoid	<i>Salmonella typhi</i>

SECTION-D : MATHEMATICS

This section contains **15 Multiple Choice Questions**. Each question has four choices (1), (2), (3) and (4) out of which **ONLY ONE** is correct.

46. Evaluate: $\frac{10(-1) - (-2)(-3)}{2[-8 \div (-2 - 2)]}$
 (1) 2 (2) -2 (3) 4 (4) -4
47. Each of the letters A,B,C,D represents different odd integers between 2 and 10. What is the least value of $\frac{A+B-C}{D}$?
 (1) $\frac{8}{9}$ (2) $\frac{6}{7}$ (3) $\frac{3}{5}$ (4) None of these

48. In figure, $AB = AC$, $\angle B = \angle C$, $AB = 8$ cm, $BE = 6$ cm and $AE = 3$ cm, then find perimeter of $\triangle ADC$.

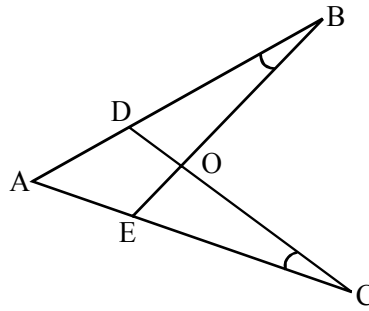

- (1) 14 cm (2) 15 cm (3) 17 cm (4) 19 cm
49. In a $\triangle ABC$, if $2\angle A = 3\angle B = 6\angle C$, then $\angle B =$ _____
 (1) 30° (2) 90° (3) 60° (4) 45°
50. When Keisha installed a fence along the 200 feet perimeter of her rectangular back yard, she left an opening for a gate. In the diagram below, she used 'X' to represent the length (in feet) of the gate.

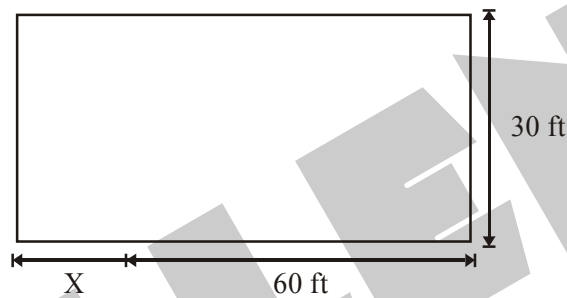

- What is the value of X?
 (1) 10 (2) 20 (3) 25 (4) 30
51. If we rotate a right angled triangle of height 10 cm and base 6 cm about its base we get
 (1) cone of height 6 cm and base diameter 10 cm.
 (2) cone of height 10 cm and base diameter 6 cm.
 (3) cone of height 10 cm and base diameter 12 cm.
 (4) cone of height 6 cm and base diameter 20 cm.
52. Between 2 positive rational numbers separated by 1 unit, there is a rational number in their midway/halfway, such that sum of all 3 rational numbers is $\frac{15}{4}$. What can be said about the three numbers?
 (1) All 3 numbers are less than 1. (2) All 3 numbers are greater than 1.
 (3) All 3 numbers are between 0 and 3. (4) None of these
53. In a parking lot there are some cars and some bikes. If there are total 70 vehicles and 200 wheels altogether, find number of bikes.
 (1) 30 (2) 40 (3) 45 (4) 50
54. In the following figure the bisector of interior angles of the parallelogram PQRS enclose a quadrilateral ABCD. Find $\angle ADC$.

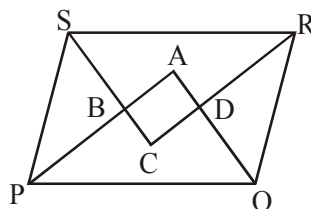

- (1) 45° (2) 90° (3) 30° (4) 60°

CLASS-VIII

55. If squares of two consecutive positive integers differ by 1987. Then sum of these integers is
 (1) 1970 (2) 1981 (3) 1987 (4) 1990
56. The square of a natural number subtracted from its cube is 48. The number is
 (1) 6 (2) 5 (3) 4 (4) 8
57. Find the value of x , if $5^{12} \div \sqrt{625} = 5^{3x+1}$.
 (1) 3 (2) 4 (3) $\frac{10}{3}$ (4) 5
58. The sum of three consecutive odd numbers and three consecutive even numbers together is 231. Also the smallest odd number is 11 less than the smallest even number. What is the sum of the largest odd number and the largest even number?
 (1) 74 (2) 81 (3) 83 (4) 87
59. Perimeter of a rhombus is 52 cm and the length of one of its diagonals is 24 cm. Find the length of its other diagonal (in cm).
 (1) 6 (2) 8 (3) 10 (4) 12
60. If the product of two irrational numbers is rational, then which of the following can be concluded?
 (1) The ratio of the greater and the smaller numbers is an integer.
 (2) The sum of the numbers must be rational.
 (3) The excess of the greater irrational number over the smaller irrational number must be rational.
 (4) None of the above

SECTION-E : MENTAL ABILITY

This section contains **20 Multiple Choice Questions**. Each question has four choices (1), (2), (3) and (4) out of which **ONLY ONE** is correct.

61. If CONTRIBUTE is written as ETBUIRNTOC, which letter will be in the sixth place when counted from the left if POPULARISE is written in that code ?
 (1) L (2) A (3) I (4) R
62. Some of the letters are missing which are given in that order as some of the alternatives below it. Choose the correct alternative.
 b – ac – cc – cb – ab – ac
 (1) cabab (2) bbaac (3) abbbc (4) aabba
63. Find the missing character :
- | | | |
|--|--|---|
| $\begin{array}{c} 42 \\ 13 \text{ } \bigcirc \text{ } 11 \text{ } 52 \\ 6 \end{array}$ | $\begin{array}{c} 84 \\ 9 \text{ } \bigcirc \text{ } 10 \text{ } 27 \\ 12 \end{array}$ | $\begin{array}{c} 44 \\ 8 \text{ } \bigcirc \text{ } ? \text{ } 72 \\ 11 \end{array}$ |
| (1) 13 | (2) 5 | (3) 8 |
| | | (4) 14 |

64. Which of the following Venn diagram correctly represents the relation among Rhombus, Quadrilateral and Polygons ?

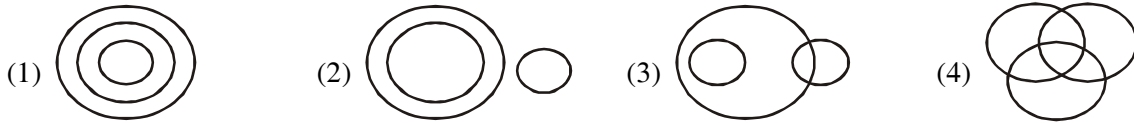

65. A cube is painted blue on all faces. It is cut into 125 smaller cubes of equal size. How many cubes are painted on one face only ?

- (1) 8 (2) 16 (3) 36 (4) 54

66. A and B are standing in a row. A is 20th from left side of the row and B is 22nd from right side of the row. If they interchange their positions A becomes 33rd from left. Find total number of persons ?

- (1) 54 (2) 44 (3) 55 (4) 53

67. Pointing to a lady, a man said, 'She is the only daughter of my mother's husband's only son'. How is the lady related to the man ?

- (1) Sister (2) Aunt (3) Daughter (4) Niece

68. Given interchanges : Signs '-' and '÷' ; numbers '4' and '8'.

- (1) $6 - 8 \div 4 = -1.0$ (2) $8 - 6 \div 4 = 1.0$
 (3) $4 \div 8 - 2 = 6.0$ (4) $4 - 8 \div 6 = 2.0$

69. At the evening time Rekha is walking on the play ground, if her shadow is towards her right then what is the facing direction of Rekha ?

- (1) North (2) South
 (3) East (4) West

70. If MASTER is coded as $\overline{411259}$, then POWDER will be coded as :

- (1) $\overline{765439}$ (2) $\overline{765439}$ (3) $\overline{765459}$ (4) $\overline{765549}$

71. A man walks 6 km to the East and then turn to the South and walk 2 km. Again he turns to the East and walks 2 km. Next he turns Northwards and walks 8 km. How far is he now from his starting point ?

- (1) 18 km (2) 10 km (3) 16 km (4) 12 km

72. Find the next figure from the given alternatives to complete the given sequence.

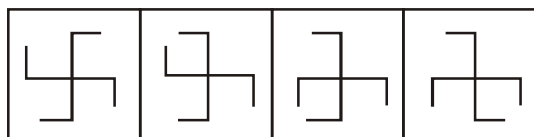

73. A cube is cut in two equal parts along a plane parallel to one of its faces. One piece is then coloured red on the two larger faces and green on the remaining, while the other is coloured green on two smaller adjacent faces and red on the remaining. Each is then cut into 32 cubes of same size and mixed up. How many cubes have only one coloured face each ?
- (1) 32 (2) 8 (3) 16 (4) 0

74. (i) $A + B$ means 'A is the father of B'
 (ii) $A - B$ means 'A is the wife of B'
 (iii) $A \times B$ means 'A is the brother of B'
 (iv) $A \div B$ means 'A is the daughter of B'

If $A - C + B$, which of the following statements is true ?

- (1) A is the mother of B
 (2) B is the daughter of A
 (3) A is the aunt of B
 (4) A is the sister of B
75. Find out the alternative figure which contains figure (X) as its part :

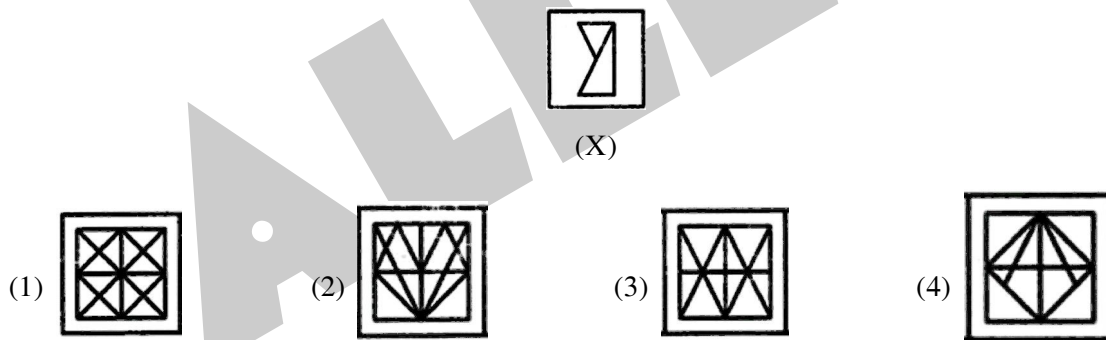

76. Find the Mirror Image of the given figure.

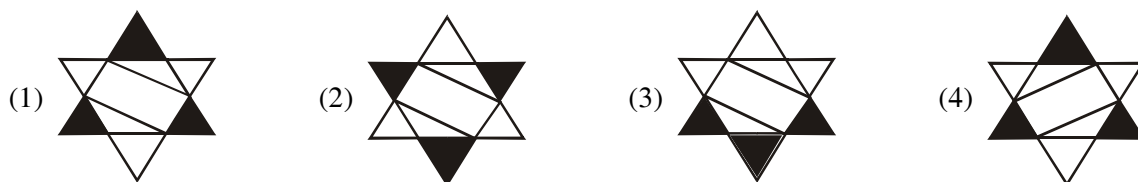

77. Find the next term in given series :

11, 13, 17, 25, 32, ?, 47

- (1) 35 (2) 40 (3) 37 (4) 39

78. Find the Water Image of the given figure.

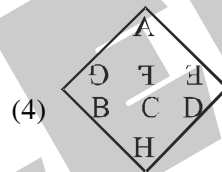
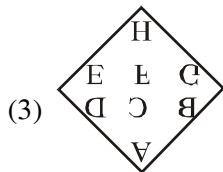
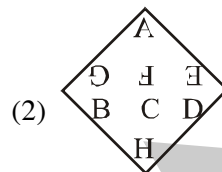
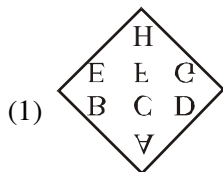
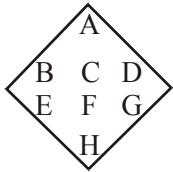

79. Count the number of parallelogram in the given figure :

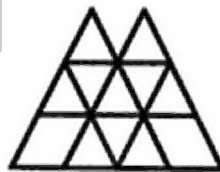

- (1) 23 (2) 22 (3) 21 (4) 18

80. There are three intersecting circles each representing certain section of people. Different regions are marked. Choose the letter of the region which represents Chinese who are painters but not musicians.

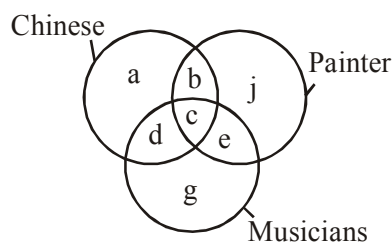

- (1) b (2) c (3) d (4) g

ANSWER KEY

Que.	1	2	3	4	5	6	7	8	9	10	11	12	13	14	15
Ans.	4	2	1	3	1	3	2	1	4	4	4	1	3	4	4
Que.	16	17	18	19	20	21	22	23	24	25	26	27	28	29	30
Ans.	3	2	4	4	4	2	1	4	1	1	4	3	2	1	4
Que.	31	32	33	34	35	36	37	38	39	40	41	42	43	44	45
Ans.	3	4	3	2	2	3	1	1	3	4	1	3	4	1	1
Que.	46	47	48	49	50	51	52	53	54	55	56	57	58	59	60
Ans.	4	4	3	3	1	4	3	2	2	3	3	1	2	3	4
Que.	61	62	63	64	65	66	67	68	69	70	71	72	73	74	75
Ans.	1	4	1	1	4	1	3	3	1	3	2	3	3	1	3
Que.	76	77	78	79	80	ALLEN									
Ans.	2	3	1	1	1										